

PART NAME

NEMA 4X ENCLOSURE

PART No.

PN-1324, PN-1324-C AND PN-1324-DG

REV. DATE

11-17-08

INDUSTRY STANDARDS:

POLYCARBONATE (LIGHT GRAY AND CLEAR)  
 UL94-HB FLAMMABILITY RATING (UL FILE #E41613)  
 UV STABILIZED  
 SERVICE TEMPERATURE RANGE: -40°C TO +120°C

ABS (DARK GRAY)  
 UL94-HB FLAMMABILITY RATING (UL FILE #E56070)  
 SERVICE TEMPERATURE RANGE: -40°C TO +80°C

(\* MOUNTING BOSSES USE EITHER M2.5 METRIC OR #4 STD. SHEET METAL SCREWS x 0.188" LG. (NOT SUPPLIED)

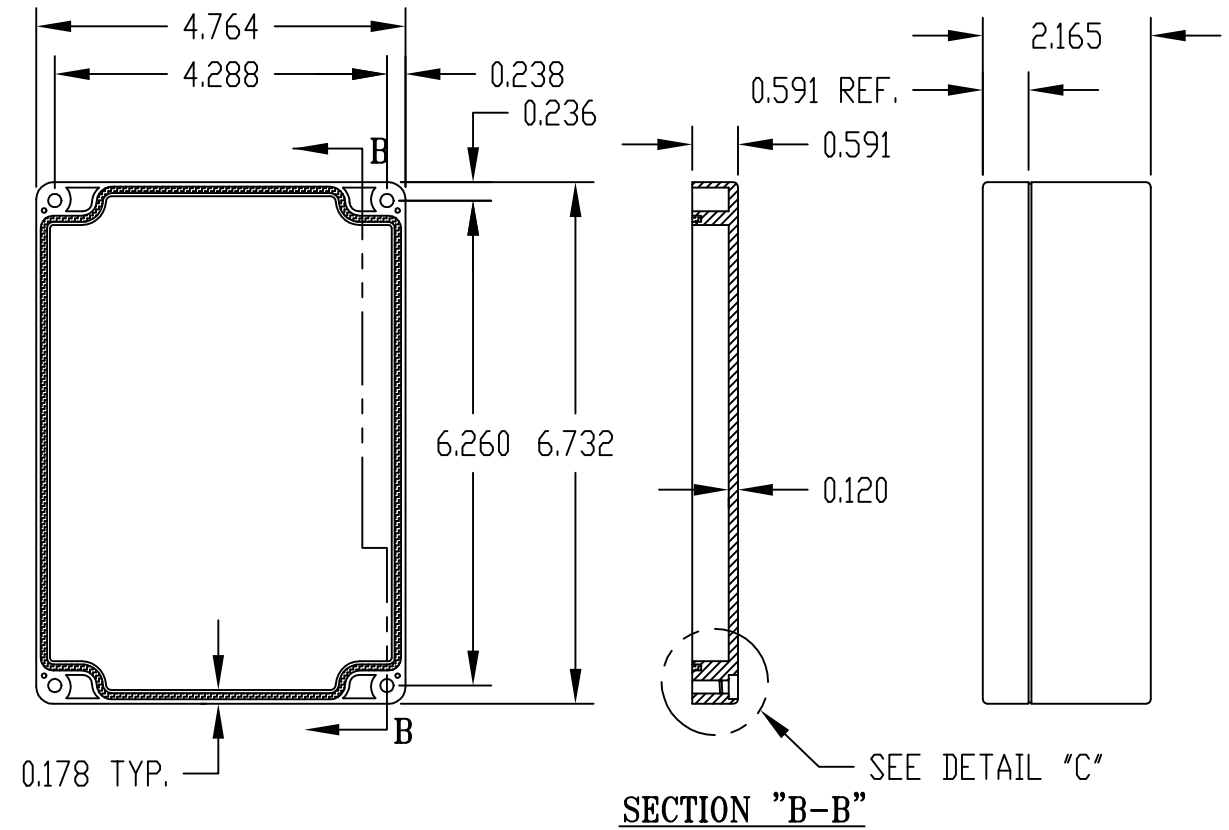
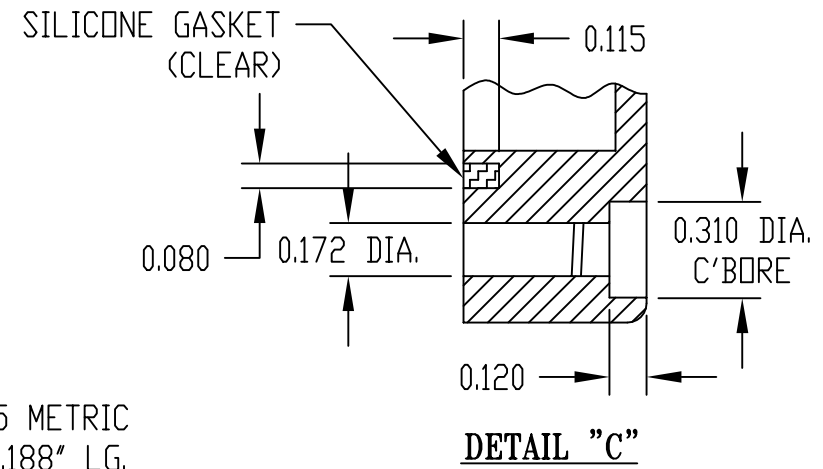
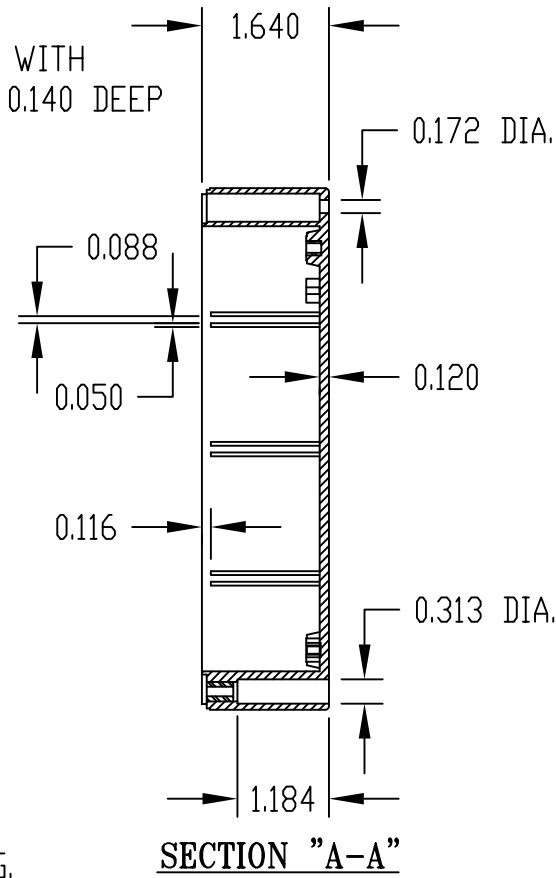
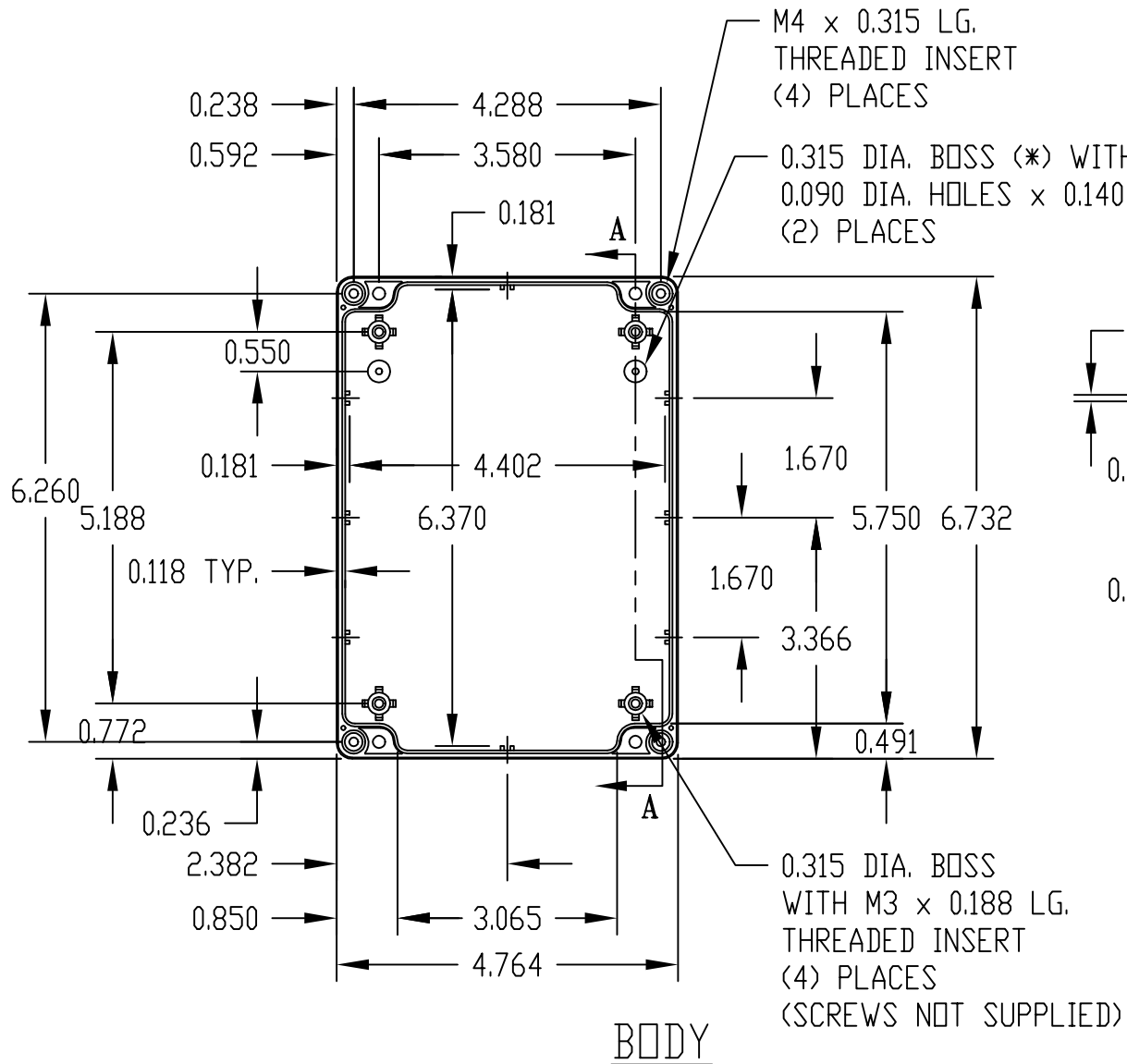

**COVER**

NOTE: ALL DIMENSIONS HAVE ±0.015 TOLERANCE UNLESS OTHERWISE SPECIFIED.

PART NUMBER	MATERIAL		FINISH		HARDWARE KIT
	BODY	COVER	BODY	COVER	
PN-1324	POLYCARBONATE		LIGHT GRAY		KIT CONTAINS (4) M4 x 20mm (0.787") LG. SCREWS FOR ASSEMBLY
PN-1324-C	POLYCARBONATE		LIGHT GRAY	CLEAR	
PN-1324-DG	HIGH-IMPACT ABS		DARK GRAY		